



## Computerized pattern machine without thread loose in initial sewing

Intelligent blowing without thread loose in initial sewing

400-8876-858  
www.chinajack.com



Jack Wechat



Jack Facebook

2022.9

### JACK SEWING MACHINE CO.,LTD.

No.1008,DonghaiAvenueEast,jiaojiangDistrict,TaizhouCity,Zhejiang  
TEL: 0086-576-88177782 88177767  
FAX: 0086-576-88177787

E-mail: sales@chinajack.com  
www.chinajack.com



JK-T3520MA-D

# JK-T3520MA-D

Item:Computerized pattern machine without thread loose in initial sewing  
 Feature:Intelligent blowing without thread loose in initial sewing

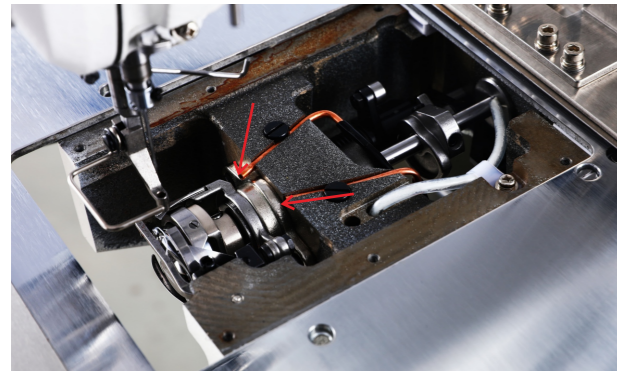

## 1 Avoid thread loose in initial sewing, stable performance

The intelligent blowing device avoid thread loose in initial sewing, reduce the abrasion of the hook, improve the sewing performance and reduce the thread breakage frequency.



## 2 Thread breakage detection, quality assurance

The machine will stop immediately when thread breakage is detected, avoid damage to the fabric by empty seams, resulting in waste and rework.

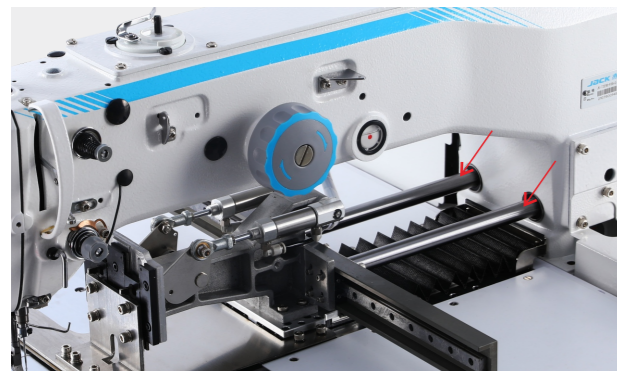

## 3 Large spacing built-in dual axis

The pressure of the pressing plate is evenly during the sewing, distributed to prevent the material from loosening, ensure the sewing stability.



## 4 High precision and ultra wide feeding guide rail

The standard width of X and Y guide rails are 15mm, especially for extremely thick sewing, the feeding is more stable and the precision is higher.

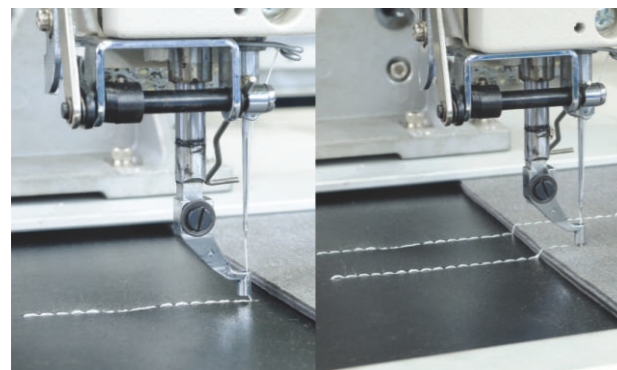

## 5 Intelligent middle presser foot, perfect sewing

The height of the middle presser foot can be set according to the fabric thickness, so as to prevent needle skipping and thread breakage, and fabric damage, (Model N is without electronic middle presser foot).

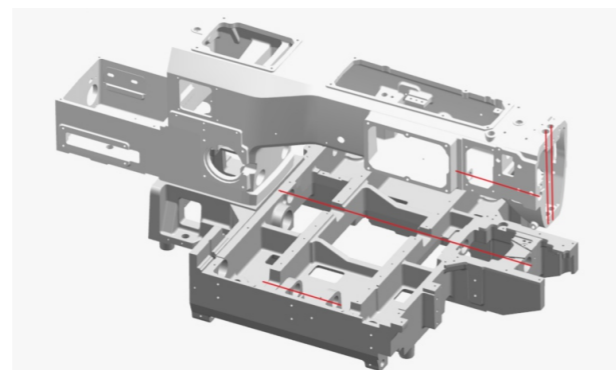

## 6 High precision machining casings and parts

Mazak machine tools imported from Japan and new integrated reaming process create high-quality casing, multi-layer painting process, self-built parts supply system, are high quality guaranteed.



## 7 Convenient and fast pattern edit and input

There are 999 kinds of USB import patterns, which can be easily edited by the computer or printed through the operation screen, it is easy to operate.

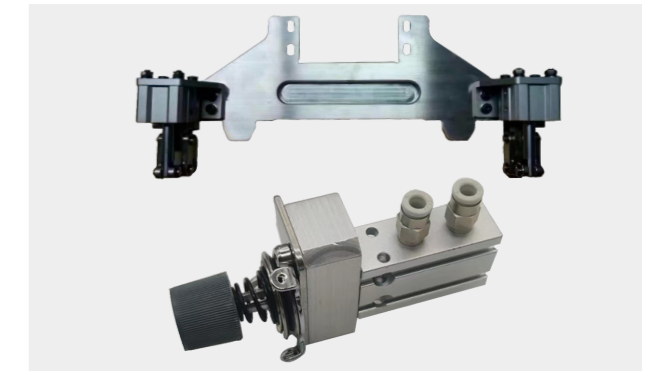

## 8 Additional devices, optional to match

For frequent template replacement processes for small parts of shoes, clamping device is optional to improve sewing efficiency; The secondary thread clamping device can be optional to improve the reverse stitch and improve the sewing quality.

## Technical parameter

Model	Bobbin thread type	Sewing Range (mm)	Needle	Needle No.	Thread No.	Stitch Length (mm)	Max middle presser foot height (mm)	Max pressure frame height (mm)	Max Speed (s.p.m)	Volume (mm)	Weight (kg)
JK-T3520MA-D	hook	350X200	Dpx17 19#	1	2	0.1-12.7	17	26	2500	1200x1220x1320	180/200
JK-T3520MA-N-D	hook	350X200	Dpx17 19#	1	2	0.1-12.7	17	26	2500	1220x1220x1320	180/200